

INTEGRIPod™ SM High Speed High Speed Stand-alone Motion Logger



INTEGRIPod™ SM HS+ high speed logger – Logger module and sensor module



Sensor module allows easy installation by ROVs or divers

The INTEGRIPod™ SM HS+ is a stand-alone motion data logger designed for high speed data logger in harsh deepwater environment. The maximum sampling frequency for acceleration measurement is 4 kHz. It records the measured acceleration into its on-board memory and the acceleration data is downloaded into a computer for subsequent data processing after the logging campaign.

The data logger contains a tri-axial accelerometer to measure acceleration in three directions. From the measurement, various parameters can be derived such as: frequency component, linear displacement and average inclination.

The INTEGRIPod™ SM HS+ is ideally used in condition monitoring for subsea pipelines, machinery and various type of subsea structures. By capturing the vibration behaviour of these structures, operators can gain understanding on the performance of their assets.

DATA LOGGER AND SENSOR MODULES

The data logging system consists of a data logger module and a light-weight sensor module. The data logger module contains all electronics and batteries enclosed in a cylindrical casing. An external sensor module is connected to the data logger via a subsea cable.

The sensor module is a small cylindrical casing containing a tri-axial accelerometer. The casing features magnetic pads which allow it to be attached to a structure made from ferric materials. The sensor assembly can be deployed by divers or ROVs.

OPERATIONS

After initialization of the logger using a computer and dedicated software, loggers can be deployed to the designated locations. The magnetic pads will enable the sensor module to be firmly attached to the structure. This may be reinforced further by applying straps over the sensor module to the structure. The data logger can be strapped to a structure or placed in a holder of a suitable design.

After a logging campaign, the data logger is retrieved. The data logger cap is opened and the memory card is removed from the logger. Then you insert the memory card into a memory reader to download data into a computer. To view acceleration data on the screen or save the acceleration into ASCII format, users can use a Pulse freeware INTEGRIVIEW™.

MAXIMUM LOGGING PERIODS EXAMPLES (TRI-AXIAL ACCELERATION)

Continuous logging @ 4 kHz	16 days (limited by memory)
Continuous logging @ 2 kHz	32 days (limited by memory)
20 minute logging every 2 hours @ 4 kHz	96 days (limited by memory)

SENSOR MODULE SPECIFICATION

G Sensors	
Sensor direction	X, Y and Z
Range [g]	± 1.2 and ± 2
Cut-off response	2000 Hz default or configurable to match logging frequency
Accuracy [g rms]	±0.006 (1.2 g range)
DC temperature drift	Calibration can be provided
Alignment error [°]	0.3 between axis
Interconnection	
Connectors	6 pin Subconn type TI connector
Subsea Cable and connector	2 m in length
Casing	
Material	Superduplex stainless steel
Size [mm]	120 diameter x 100 high (main body)
Weight in air/water [kg]	8 / 7
Pull Force to remove module [kg]	-40
Environmental	
Operating [° C]	2 to 30
Storage [° C]	-4 to 85
Pressure rating [m]	3000 water depth
Seals	3 'O-rings' seals for the cap



Software to initialise the data logger

LOGGER SPECIFICATION

Analogue inputs

Number of inputs 8 analogue inputs, 16 bit
 Input range [V] -2.5 to + 2.5
 Accuracy [mV, rms] 0.14
 Resolution [mV] 0.076

Logger communication

Connection RS232 (serial port)

On-board memory

Memory media 32 GB compact flash memory card

Power supply

Battery type D-size 3.6V Lithium
 Batteries configuration 4 batteries in series to give 14.4 V
 14 of the above in parallel
 Capacity [mA-hour] 189,000 total (nominal)
 Current in logging [mA] 160 (including tri-axial sensors)
 Standby [mA] 15

Sampling frequency

Frequency [Hz] 4000, 2000, 1000, 400, 200, 100
 Error <+/- 0.2% of frequency

Logging programme

Logging mode Continuous and intermittent
 Intermittent mode
 Logging period [minute] 1, 10, 15, 20, 30
 Cycle period [hour] 0.5, 1, 1.5, 2, 2.5, 3, 4, 5, 6

Casing

Material Superduplex stainless steel
 Size [mm] 114 diameter x 870 length
 Weight in air [kg] 20 (with batteries)
 Weight in water [kg] 15 (with batteries)

Interconnection

Connectors 6 pin Subconn type connectors

Environmental

Operating temp [° C] 2 to 30
 Storage temp [° C] -4 to 85
 Pressure rating [m] 3000 water depth
 Seals 3 'O-rings' on caps

Software

Operating system Windows 2000, NT, XP, Vista
 Functions
 -Diagnostic check
 -Initialise loggers
 -On-line logging
 -Battery and memory life calculation

Format of data files

Downloaded file (RAW)
 -Time stamp
 -Binary format for all data
 Calibrated output data ASCII format

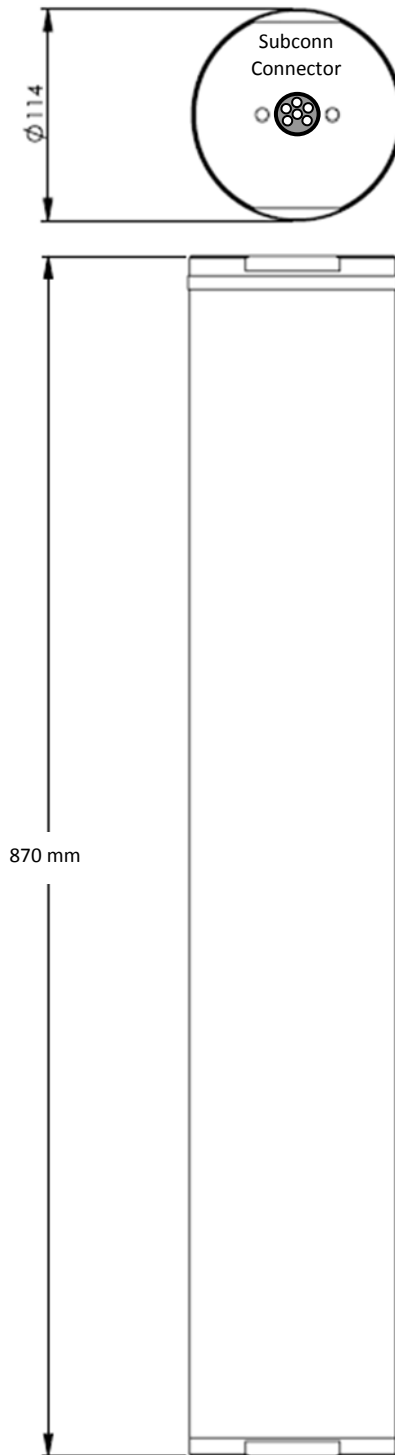

Logger holder to take the data logger

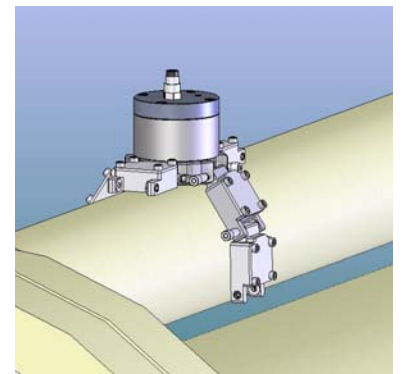

Sensor Module (114 mm in diameter and 100 mm in height) with magnetic pads



London
 1-7 Cherry Street
 Surrey, GU21 6EE, UK
 Tel: +44 1483 774910

Aberdeen
 Tern Place House, Tern Place,
 Bridge of Don
 Aberdeen, AB23 8JX, UK
 Tel: +44 1224 452285

Houston
 16000 Barkers Point Lane, Suite 120,
 Houston, TX 77079, USA
 Tel: +1 713 422 2663

Kuala Lumpur
 Suite 16-3, 16th Floor, Wisma UOA II
 21 Jalan Panang 50450
 Kuala Lumpur, Malaysia
 Tel: +60 1 2328 312

Rio de Janeiro
 Praça Floriano, 19-22º andar,
 Centro, RJ, 20031-924, Brazil
 Tel: +55 21 2510 7323